

- Complies with American National Standard Z358.1-2004
- Shower Activation Handle is Fully Recessed
- Sturdy One-Piece Cabinet for Quick and Easy Installation
- Full, One-Year Warranty
- Patent Pending



Specifications

Barrier-free design makes this shower and eyewash fully accessible to people with physical disabilities. Unit is flush-mounted into the wall. This unit is designed to accommodate areas where space considerations are a concern. Such areas may include, but are not limited to, laboratories, hospitals, and schools. Shower activation handle does not break the plane of the wall. This ensures no obstructions protrude from the wall. Shower valve activates when handle is pushed downward. No tight pinching or grasping is required. Showerhead is designed for varying water supply pressures of 30–90 PSI ensures a minimum flow of 20 GPM for ANSI compliance. Eyewash operates by pulling cabinet door down. Water is collected by the door assembly and directed back into the wall for drainage. Eyewash has an integral flow control in the shank.

- ANSI Z358.1 compliant drench showers are mounted between 82"-96" from the lower edge of the showerhead or shroud to the floor.

Installation

A rough wall opening of 25-5/8"W x 32-1/8"H x 4"D is required. Frame is integral to the unit. Secure unit to framing with screws (supplied by installer) at the holes provided.

Standard Equipment

Cabinet and Door

Stainless Steel. Hinged locked door conceals stop valve, tailpiece and eye/face wash fittings.

SpinTec™ Showerhead

3.1" (78.7mm) diameter highly visible yellow impact-resistant plastic with optional 10-3/4" (273mm) diameter corrosion-resistant stainless steel shroud. SpinTec drench showerhead features integral 23 GPM flow control, conserving water and helping to accurately size your tepid water system.

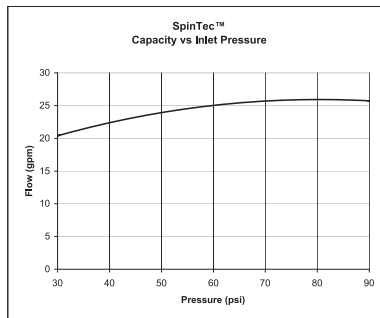

Shower Valve

Chrome-plated brass 1" NPT stay-open ball valve. Hand operated by a black powder-coated stainless steel handle when pushed downward.

Eye/Face Wash Valve

Chrome-plated brass 1/2" NPT stay-open ball valve. Water flow is activated by pulling the door down 90 degrees with supplied handle. Water will continue to flow until door is returned to its original position.

Eye/Face Wash Sprayhead Assembly

Chrome-plated brass sprayhead assembly with twin soft-flow eyewash heads and protective sprayhead covers. Safe, steady water flow under varying water supply conditions from 30–90 PSI is assured by integral flow control in the sprayhead assembly. NOTE: The ANSI Z358.1 standard requires an uninterrupted supply of flushing fluid at a minimum 30 PSI flowing pressure.

Pipe and Fittings

1" copper piping, brass and chrome-plated fittings. Piping is supplied by others.

Water Supply

1" NPT for drench shower, 1/2" NPT for eyewash.

Eyewash Waste

1-1/4" drain is provided with tailpiece (models S19-325BF and S19-325FBF) or optional P-trap (models S19-325PBF and S19-325FPBF).

- A 4" floor drain is recommended for drench shower waste (supplied by others).

Recommended Option:
 Navigator S19-2100 EFX25
 Emergency Thermostatic Mixing Valve
NAVIGATOR

Satisfies ANSI Z358.1-2004 tepid water requirements.

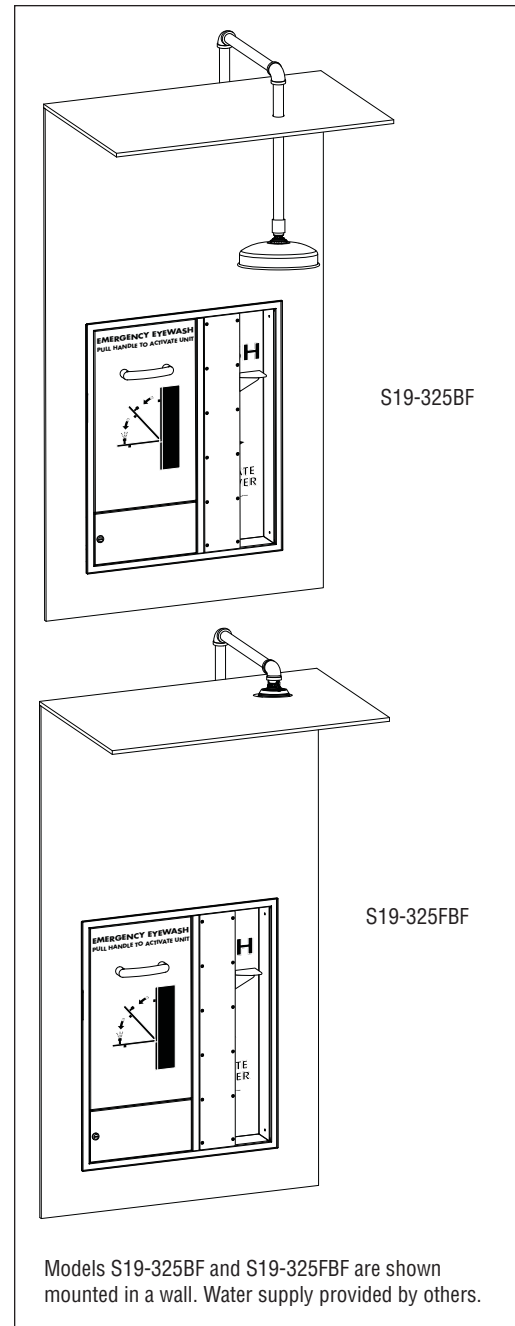

Models S19-325BF and S19-325FBF are shown mounted in a wall. Water supply provided by others.

Model	Description
<input type="checkbox"/> S19-325BF	Barrier-Free Recessed Drench Shower and Eye/Face Wash with Recessed Shower Handle, Extended Showerhead and Tailpiece
<input type="checkbox"/> S19-325FBF	Barrier-Free Recessed Drench Shower and Eye/Face Wash with Recessed Shower Handle, Flush-Mounted Showerhead and Tailpiece
<input type="checkbox"/> S19-325PBF	Barrier-Free Recessed Drench Shower and Eye/Face Wash with Recessed Shower Handle, Extended Showerhead and P-trap
<input type="checkbox"/> S19-325FPBF	Barrier-Free Recessed Drench Shower and Eye/Face Wash with Recessed Shower Handle, Flush-Mounted Showerhead and P-trap
<input type="checkbox"/> S19-2100	Navigator EFX25 - Emergency Thermostatic Mixing Valve

