

ENG. NO. 84708-D
 PAT. NO. 5,011,074.
 PAT. NO. 5,203,496.
 PAT. NO. 5,323,960.
 PAT. NO. 5,647,531.

Thermostatic Mixing Valve Model SE-352 Emergency Showers Unit No. SE-352

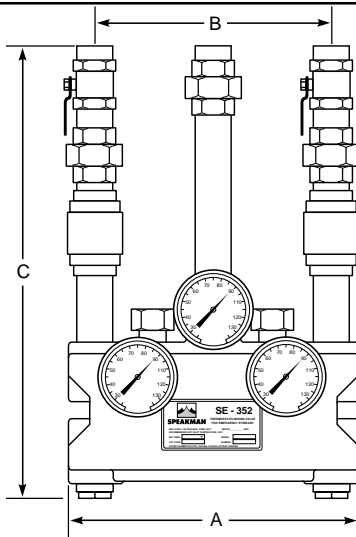

Inlet & Outlet 1 1/4" N.P.T.
 Allow for 5" Depth

The Emergency Shower Mixing Valve shall employ two fully independent control mechanisms which split the flow in half, blend each half to the design temperature and then integrate each stream at the outlet. The valve shall control outlet temperature over a wide range of flow and shall be suitable for deluge shower or eyewash applications. The valve shall include three thermometers to measure the temperature of each stream and the merged flow. Temperature adjustment shall be vandal resistant.

Each independent control mechanism shall employ a liquid filled thermostatic motor to drive the valve without additional power requirements. Each control mechanism shall employ a stainless steel sliding piston control device with reverse seat closure and both fixed and variable cold water bypass.

In the event of interruption of the cold water supply, each control mechanism closes off the hot water port, stopping all flow.

In the event of interruption of the hot water supply, each control mechanism shall allow cold flow through both the fixed and variable bypass.

In the event that one liquid motor fails, the control mechanism closes off the hot water port with the reverse seat and fully opens the internal variable bypass to allow cold water flow. The other control mechanism will be unaffected by the failure and will maintain design temperature.

- Maximum Inlet Pressure:** 125 PSI.
- Minimum Supply Pressure:** 35 PSI.
- Recommended Operating Pressure:** 65 PSI.
- Maximum Inlet Temperature:** 180°F.
- Recommended Inlet Temperature:** 120°F-140°F.-

- VALVE FINISH**
 Rough Bronze Chrome Plate
- TEMP. RANGE** **SET POINT**
 70° to 90°F 85°F

DIMENSIONS:

Valve Number	A	B	C
SE-352	11"	9"	16"

CAPACITY OF THERMOSTATIC MIXING VALVE FOR EMERGENCY SHOWERS

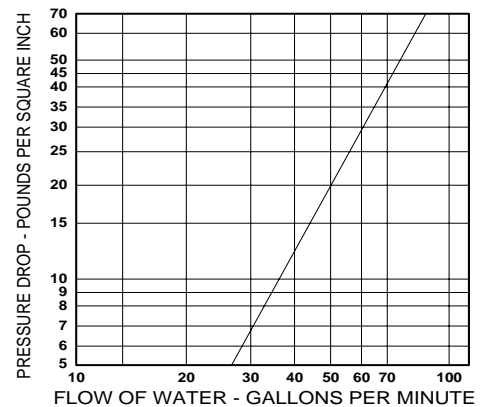

CAPACITIES - MODEL SE-352

Pressure Drop PSI	5	10	20	30	45	60	80
Valve Number	Capacity-GPM						
SE-352	25	35	50	60	72	84	95

Lock set Mounting Bracket

Lock set includes lock for each ball valve and lockable cover plate to prevent unauthorized temperature adjustment.

Unit includes 0-200°F dial thermometer, inlet check valves, lockable ball valves and unions.

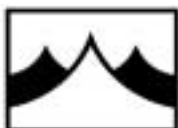

SPEAKMAN COMPANY
 The Difference Is The Experience
 P.O. Box 191, Wilmington, DE 19899-0191
 Phone: 800-537-2107 Fax: 800-977-2747

Specification subject to change without notice.